

PX1520 ALUMINUM FIT PUMP

76 mm (3") Pump
Maximum Flow Rate:
984 lpm (260 gpm)

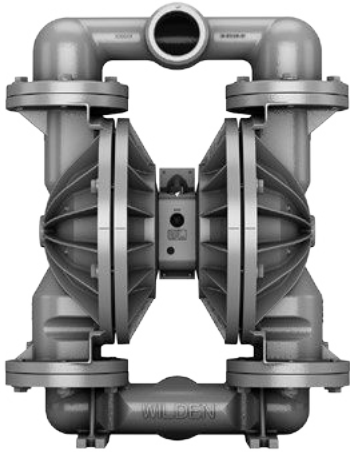

DIMENSIONAL DRAWING

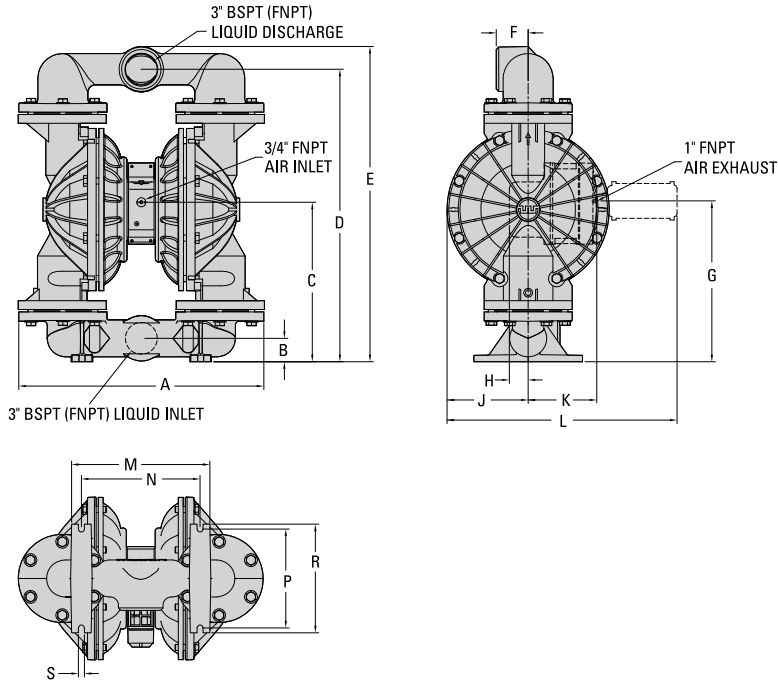

DIMENSIONS

ITEM	METRIC (mm)	STANDARD (inch)
A	635	25.0
B	61	2.4
C	414	16.3
D	759	29.9
E	818	32.2
F	84.0	3.3
G	417	16.4
H	48	1.9
J	211	8.3
K	178	7.0
L	597	23.5
M	358	14.1
N	307	12.1
P	257	10.1
R	282	11.1
S	15	0.6

LW0095 REV. B

PUMP DATA

Specifications:

- Height..... 1,031 mm (40.6")
- Width..... 615 mm (24.2")
- Depth..... 422 mm (16.6")
- Ship Weight 70 kg (152 lb)
- Air Inlet..... 19 mm (3/4")
- Liquid Inlet..... 76 mm (3")
- Liquid Outlet..... 76 mm (3")

PX1520 ALUMINUM FIT PUMP

PERFORMANCE

**PX1520 ALUMINUM
EZ-INSTALL TPE-FITTED**

Max. Flow Rate.....984 lpm (260 gpm)
 Max. Inlet Pressure8.6 bar (125 psig)
 Max. Solids Passage..... 12.7 mm (1/2")
 Max. Suction Lift6.6 m Dry (21.7')
 8.8 m Wet (28.9')

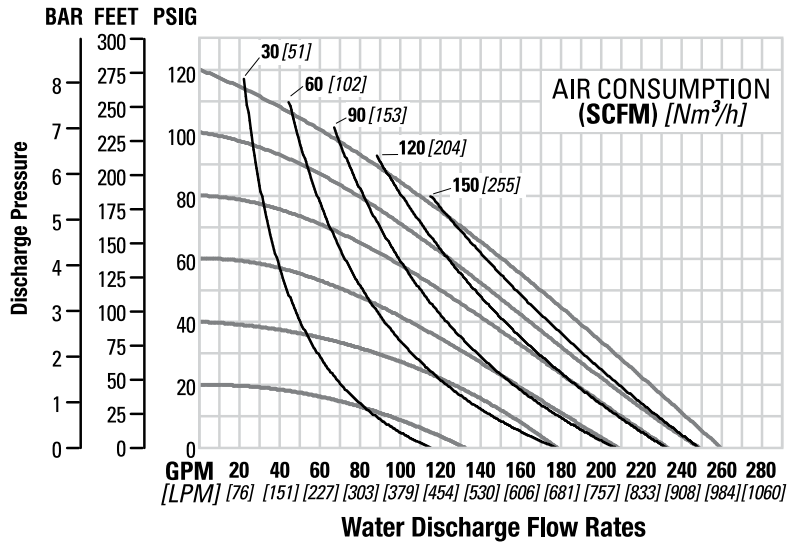

**PX1520 ALUMINUM
FULL-STROKE PTFE-FITTED**

Max. Flow Rate.....974 lpm (257 gpm)
 Max. Inlet Pressure8.6 bar (125 psig)
 Max. Solids Passage..... 12.7 mm (1/2")
 Max. Suction Lift6.4 m Dry (21.0')
 9.0 m Wet (29.5')

