

## PX220/PX230 FIT METAL PUMP

**25 mm (1") Pump**  
**Maximum Flow Rate:**  
**212 lpm (56 gpm)**

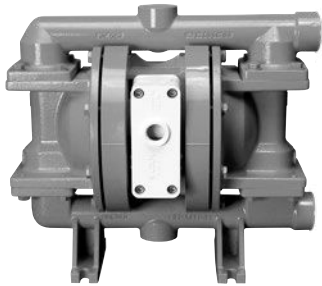

**PX220 METAL**

### DIMENSIONAL DRAWINGS

#### PX220 Metal – Center-Ported

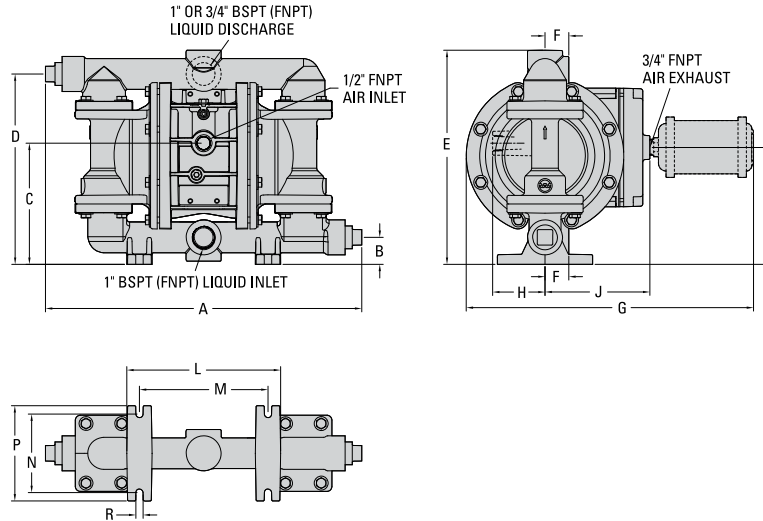

#### DIMENSIONS

ITEM	METRIC (mm)	STANDARD (inch)
A	422	16.6
B	36	1.4
C	163	6.4
D	254	10.0
E	287	11.3
F	33	1.3
G	384	15.1
H	71	2.8
J	140	5.5
K	155	6.1
L	206	8.1
M	173	6.8
N	104	4.1
P	127	5.0
R	10	0.4

LW0449 REV. A

### PUMP DATA

#### Specifications:

- Ship Weight.....Aluminum 15 kg (34 lb)
- Ductile Iron 26 kg (57 lb)
- 316 Stainless Steel 28 kg (61 lb)
- Air Inlet .....13 mm (1/2")
- Liquid Inlet.....25 mm (1")
- Liquid Outlet.....25 mm (1")

#### PX230 Stainless Steel

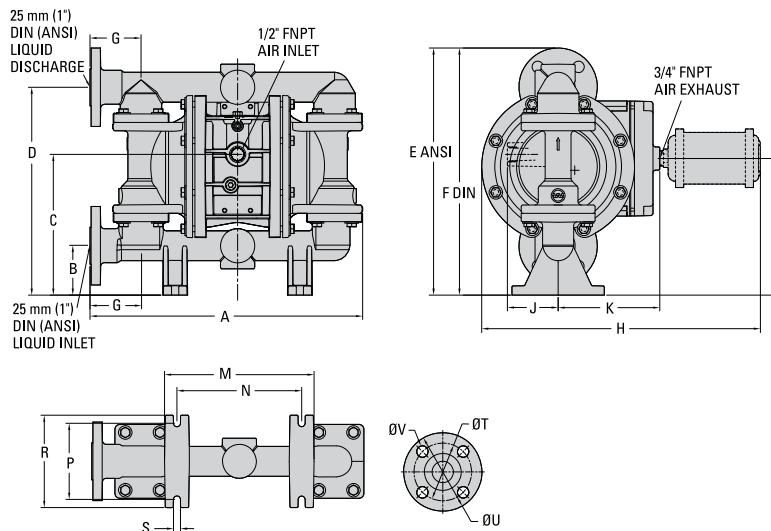

#### DIMENSIONS

ITEM	METRIC (mm)	STANDARD (inch)
A	373	14.7
B	69	2.7
C	195	7.6
D	287	11.3
E	340	13.4
F	343	13.5
G	71	2.8
H	384	15.1
J	71	2.8
K	140	5.5
L	188	7.4
M	206	8.1
N	173	6.8
P	104	4.1
R	127	5.0
S	10	0.4

#### DIN FLANGE

T	85 DIA.	3.3 DIA.
U	115 DIA.	4.5 DIA.
V	14 DIA.	0.6 DIA.

#### ANSI FLANGE

T	79 DIA.	3.1 DIA.
U	109 DIA.	4.3 DIA.
V	14 DIA.	0.6 DIA.

LW0450 REV. A

