

PX820/PX830 ALUMINUM FIT PUMP

51 mm (2") Pump  
 Maximum Flow Rate:  
 650 lpm (172 gpm)



PX820 ALUMINUM

[CLICK TO VIEW MODEL](#)

DIMENSIONAL DRAWING

PX820 Aluminum

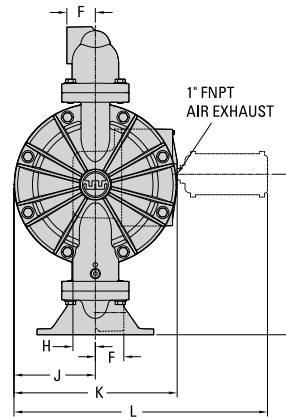
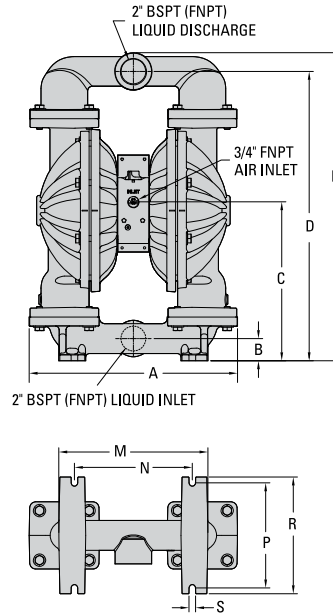

DIMENSIONS

ITEM	METRIC (mm)	STANDARD (inch)
A	453	17.9
B	48	1.9
C	346	13.6
D	630	24.8
E	670	26.4
F	62	2.4
G	349	13.8
H	49	1.9
J	177	7.0
K	355	14.0
L	552	21.7
M	324	12.8
N	257	10.1
P	229	9.0
R	254	10.0
S	14	0.6

LW0178 REV. A

PUMP DATA

Specifications:

- Height..... 820 Threaded 670 mm (26.4")  
 830 Flanged 752 mm (29.6")
- Width..... 452 mm (17.8")
- Depth..... 353 mm (14.0")
- Ship Weight.... 820 Threaded 47 kg (104 lb)  
 830 Flanged 54 kg (118 lb)
- Air Inlet ..... 19 mm (3/4")
- Liquid Inlet..... 51 mm (2")
- Liquid Outlet..... 51 mm (2")

PX830 Aluminum

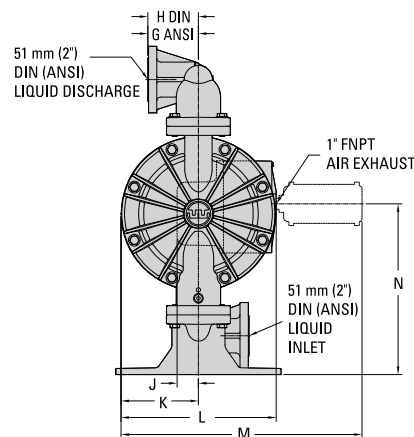
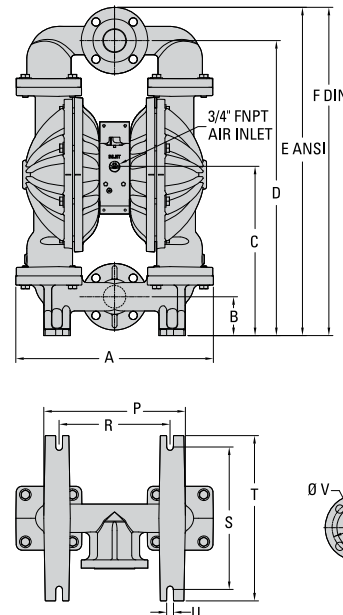

DIMENSIONS

ITEM	METRIC (mm)	STANDARD (inch)
A	452	17.8
B	89	3.5
C	388	15.3
D	675	26.6
E	752	29.6
F	758	29.8
G	116	4.6
H	117	4.7
J	49	1.9
K	177	7.0
L	355	14.0
M	552	21.7
N	391	15.4
P	324	12.8
R	254	10.0
S	326	12.8
T	378	14.9
U	16	0.6
	DIN (mm)	ANSI (Inch)
V	165 DIA	6.0 DIA
W	125 DIA	4.8 DIA
X	18 DIA	0.8 DIA

LW0179 REV. A

**PX820/PX830 ALUMINUM FIT PUMP**

**PERFORMANCE**

**PX820/PX830 ALUMINUM  
EZ-INSTALL TPE-FITTED**

Max. Flow Rate.....650 lpm (167 gpm)  
 Max. Inlet Pressure .....8.6 bar (125 psig)  
 Max. Solids Passage..... 6.4 mm (1/4")  
 Max. Suction Lift .....6.2 m Dry (20.4')  
   9.7 m Wet (31.8')

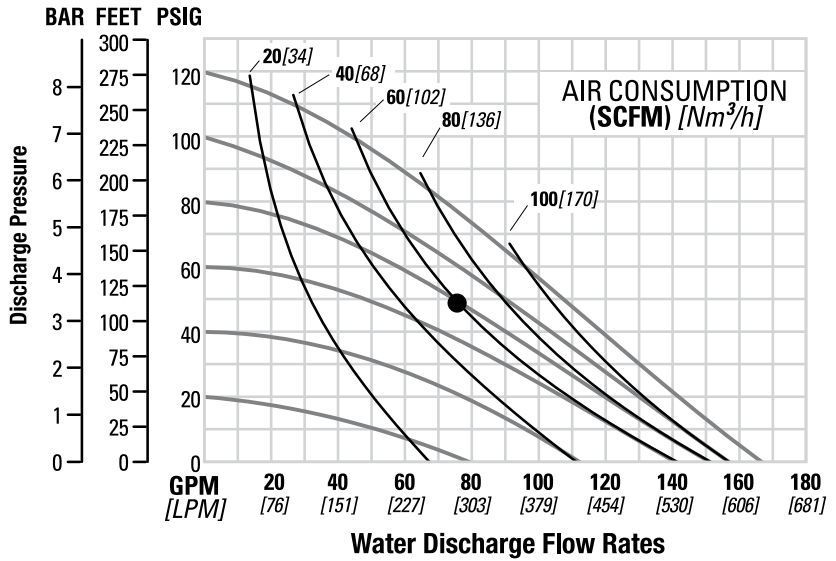

**PX820/PX830 ALUMINUM  
FULL-STROKE PTFE-FITTED**

Max. Flow Rate.....650 lpm (172 gpm)  
 Max. Inlet Pressure .....8.6 bar (125 psig)  
 Max. Solids Passage..... 6.4 mm (1/4")  
 Max. Suction Lift .....6.2 m Dry (20.4')  
   9.0 m Wet (29.5')

